

# Temperature Sensor and Build-In System

## Application

- remove the sensor without opening the process and without disconnecting
- temperature measurement, especially in pipes with very small diameters
- suitable for pipes DN10... DN100

## Examples of use

- process monitoring
- monitoring of CIP-/ SIP-cleaning
- temperature monitoring in hot steam- and pressurepipes

## Hygienic Design / Process Connection

- by using Negele build-in system ESP... will result a measure point which is hygienic and easy to sterilize
- CIP-/ SIP-cleaning up to 140°C
- food compatible materials according to FDA
- short mounting time with orbital-welder
- sensor completely made of stainless steel

## Features

- short reaction time, very compact measure point
- available with and without integrated transducer
- electrical connection by M12 plug-in (TFP-168p)
- material stainless steel (1.4435), material certificate 3.1.B for all mounting accessories inclusive

## Options / Accessories

- readymade connecting cable for M12 plug-in
- integrated transducer with different ranges, output 4-20mA
- programable integrated transducer mpu-4p for TFP-58p
- adapter for programming mpu-p (only for mpu-4p)
- integr. transducer Profibus PA mpu-10, HART-protocol mpu-H (TFP-58p)
- integrated transducer for EX-zone
- integrated LC-Display mpu-LCD in the connecting head
- Pt100-Chip with other classes of accuracy, e.g. 1/3 DIN B, 1/10 DIN B
- 2x Pt100



TFP-168p/037/m  
with SS identification  
plate



TFP-168p/037  
with ESP-W



TFP-58p/037/mpu-4 with ESP-G

Important information: Use only Negele weld-in systems, to guarantee a safety function of the measurement point!

## Specification

Process connection	immersion sleeve	G3/8" external thread
Insertion length	standard	37, 59, 83, 160mm
Materials	head	stainless steel SS (1.4305)
	protection tube	SS (1.4404)
	nut	SS (1.4571)
	neck tube	SS (1.4301) 10mm dia.
Temperature ranges	ambient	-50...+80°C
	sensor tip	-50...+250°C
Operating pressure		40 bar max.
Type of protection		IP69K

Sensing resistor	acc. to ITS 90	1xPt100 class A
Electr. connection	TFP-58p	PG (M16x1,5) or M12 plug-in SS
	TFP-168p TFP-188p	M12 plug-in SS cable (teflon) standard: 2,5m
Integrated transducer mpu-m		
Temperature ranges	standard	-10...+40, 0...100°C, 0...150°C
Accuracy		<±0,2% of full value
Temperature drift	zero point, slope	<0,02% o. f. s. /K
Electr. connection	supply voltage	12...36VDC
Output	analog	4-20mA

## Order Code

Temperature sensor	Model	Insertion length	Transducer	Ranges mpu	Electr. connection
TFP-58p	head 55mm dia.	037 37mm	x without	-10...+40°C	PG or M12 plug-in M12 plug-in fixed cable
TFP-168p	M12-connector	059 59mm	m with mpu-m	0...50°C	
TFP-188p	fixed cable	083 83mm	mpu-4; mpu-4p	0...100°C	
		160 160mm	mpu-4-ex; ...-H-ex mpu-H (HART) mpu-10 (Profibus) mpu-LCD (display)	0...150°C 0...200°C xx...yy°C (special)	

Order example: TFP-58p / 037 / mpu-4 / 0...150°C / M12

# Electrical Connection / Drawings

## Connecting Plan with M12 plug-in

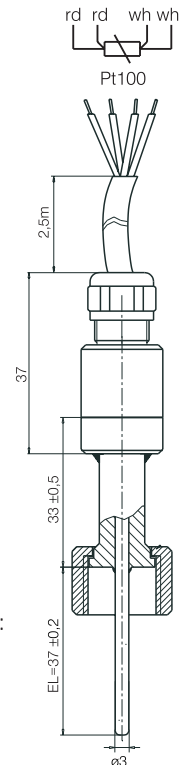
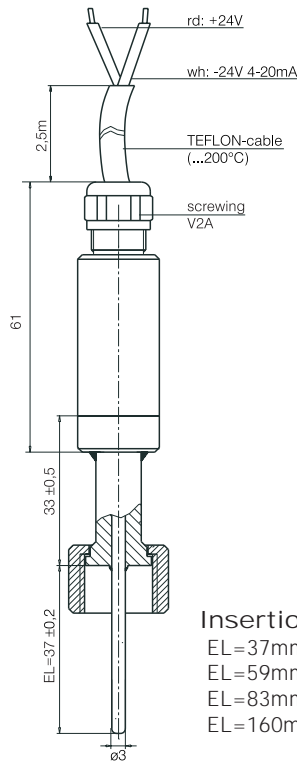
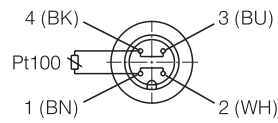
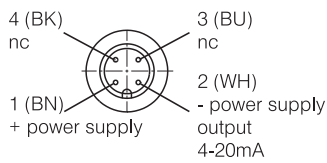

Insertion lengths:  
EL=37mm  
EL=59mm  
EL=83mm  
EL=160mm

TFP-168p/037/m with integrated transmitter mpu-m

TFP-168p/037

TFP-188p/037/m with integrated transmitter mpu-m

TFP-188p/037

## Connecting Plan TFP58p/...

without transmitter

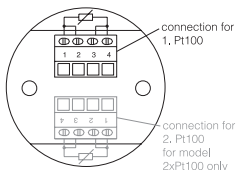

with transmitter mpu-4

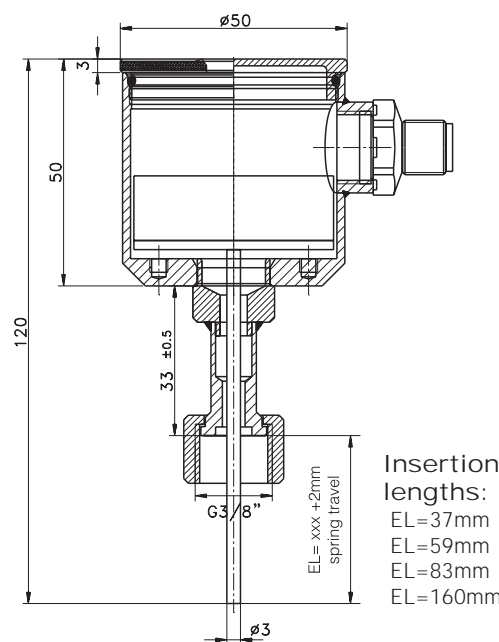
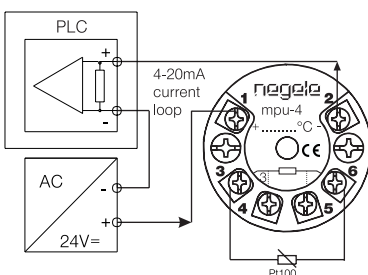

Insertion lengths:  
EL=37mm  
EL=59mm  
EL=83mm  
EL=160mm



Option integrated LC-Display mpu-LCD  
(see separate product information in chapter 2)

TFP-58p/037/mpu-4/M12 with integrated transmitter mpu-4

Build-In-Systems / Adapters (dimensioned drawings see page 8)



for BioControl  
ESP-B



for TriClamp  
ESP-C



for Varivent  
ESP-V



Thermowell  
ESP-E



Extension  
ESP-VL

## Specification

Material	pipes and sleeves	stainless steel SS (1.4435, 316L) with 3.1.B	Delta Ferrite DF	standard	<1,0% (weld seam <3%)
Surfaces	product contacted areas	$R_a \leq 0,8 \mu\text{m}$ (not in welded areas) electro-polished		option	<0,5% (weld seam <3%) (BN II)
	option	$R_a \leq 0,6 \mu\text{m}$ ; $R_a \leq 0,4 \mu\text{m}$		Baseler Norm II	(BN II)
			Sulfure Content	standard	0.030% max.
				acc. to ASME	0.005% min. 0.017% max. (see descr. page 7)
			Nominal diameter	standard	see separate tables
			Tolerances	DN10...DN40	DN: $\pm 0,3$ ; L: $\pm 1,0\text{mm}$
				DN50...	DN: $\pm 0,5$ ; L: $\pm 1,0\text{mm}$
			Sensor connection	thread	G3/8"
			Sealing principle		immersing sleeve
			Operating pressure		40bar max.

## Note

DF values are valid for delivery condition. Mechanical treatment after delivery can increment the DF value. Customized constructions are available.

## Order Code

Model	Type	Surface	Delta Ferrite	Sulfure Content
BioControl DN25	ESP-B-25 (for TFP-.../059)	0,8 $R_a \leq 0,8 \mu\text{m}$	x <1,0%	x <0,030%
BioControl DN50	ESP-B-50 (for TFP-.../059)	0,6 $R_a \leq 0,6 \mu\text{m}$	0,5 <0,5%	SA acc. to ASME
BioControl DN65	ESP-B-65 (for TFP-.../059)	0,4 $R_a \leq 0,4 \mu\text{m}$	BN Baseler Norm II	
TriClamp 1,5"	ESP-C-083 (for TFP-.../083)			
Varivent DN25	ESP-V-25-037 (for TFP-.../037)			
Varivent DN40	ESP-V-40-037 (for TFP-.../037)			
Varivent DN40	ESP-V-40-059 (for TFP-.../059)			
Thermowell	ESP-E-083 (for TFP-.../083) ESP-E-160 (for TFP-.../160)			
Extension for ESP	ESP-VL-046 (extension 46mm) ESP-VL-123 (extension 123mm)			
Order example:	ESP - B - 25 - 10 / 0,6 / x / S			

## Drawings

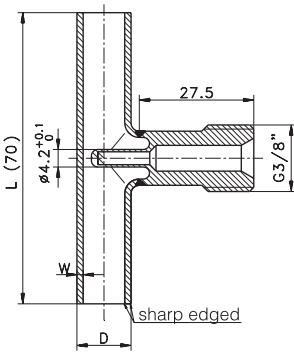

Build-in system  
ESP-G... DN10-20

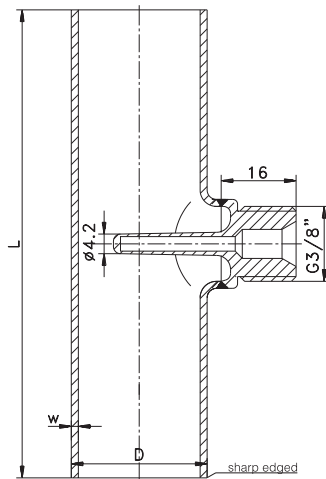

Build-in system  
ESP-G... DN25-50

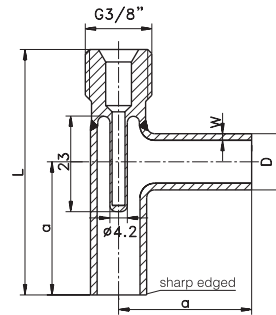

Build-in system  
ESP-W... DN10-15

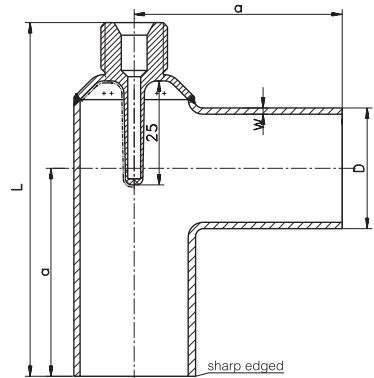

Build-in system  
ESP-W... DN20-25



TFP-168p/037/m  
with ESP-G DN10



TFP-168p/037/m  
with ESP-G DN25



TFP-168p/037/m  
with ESP-W DN8



TFP-58p/037/m  
with ESP-G DN25

## Specification

Style pipe	DIN 1	DIN 11850 series 1
	DIN 2	DIN 11850 series 2
	ISO	DIN 11866 series A
	ASME	DIN 11866 series B
Material	pipes and sleeves	stainless steel SS (1.4435, 316L) with 3.1.B
	option	OD-Tube
Surfaces	product contacted areas	$R_a \leq 0,8\mu\text{m}$ (not in welded areas)
	option	electro-polished $R_a \leq 0,6\mu\text{m}$ ; $R_a \leq 0,4\mu\text{m}$

Delta Ferrite DF	standard	<1,0% (weld seam <3%)
	option	<0,5% (weld seam <3%)
	Baseler Norm II	(BN II)
Sulfure Content	standard	0.030% max.
	acc. to ASME	0.005% min. 0.017% max. (see descr. page 7)
Nominal diameter	standard	see separate tables
Tolerances	DN10...DN40	DN: $\pm 0,3$ ; L: $\pm 1,0\text{mm}$
	DN50...	DN: $\pm 0,5$ ; L: $\pm 1,0\text{mm}$
Sensor connection	thread	G3/8"
Sealing principle		immersing sleeve
Operating pressure		40bar max.

## Note

DF values are valid for delivery condition. Mechanical treatment after delivery can increment the DF value.

## DIN 11850 Series 1

DIN 11850 Series 1				
Order Code	DN	L [mm]	Pipe Dxw	for insertion length
ESP-G-DIN1-10	10	70	12 x 1,0	TFP-.../ 037
ESP-G-DIN1-15	15	70	18 x 1,0	TFP-.../ 037
ESP-G-DIN1-20*	20	80	22 x 1,0	TFP-.../ 037
ESP-G-DIN1-25	25	100	28 x 1,5	TFP-.../ 037
ESP-G-DIN1-32*	32	110	34 x 1,5	TFP-.../ 037
ESP-G-DIN1-40	40	120	40 x 1,5	TFP-.../ 037
ESP-G-DIN1-50	50	140	50 x 1,5	TFP-.../ 037

\* This item is no standard.

DIN 11850 Series 1					
Order Code	DN	a [mm]	L [mm]	Pipe Dxw	for insertion length
ESP-W-DIN1-10	10	30	57	12 x 1,0	TFP-.../ 037
ESP-W-DIN1-15	15	35	64,5	18 x 1,0	TFP-.../ 037

## DIN 11866 Series B, ISO 1127

DIN 11866 Series B / ISO 1127				
Order Code	DN	L [mm]	Pipe Dxw	for insertion length
ESP-G-ISO-8	8	64	13,5 x 1,6	TFP-.../ 037
ESP-G-ISO-10	10	68	17,2 x 1,6	TFP-.../ 037
ESP-G-ISO-15	15	72	21,3 x 1,6	TFP-.../ 037
ESP-G-ISO-20	20	110	26,9 x 1,6	TFP-.../ 037
ESP-G-ISO-25	25	120	33,7 x 2,0	TFP-.../ 037
ESP-G-ISO-32	32	130	42,4 x 2,0	TFP-.../ 037
ESP-G-ISO-40	40	130	48,3 x 2,0	TFP-.../ 037
ESP-G-ISO-50	50	180	60,3 x 2,0	TFP-.../ 037
ESP-G-ISO-65	65	220	76,1 x 2,0	TFP-.../ 037
ESP-G-ISO-80	80	260	88,9 x 2,3	TFP-.../ 083

DIN 11866 Series B / ISO 1127					
Order Code	DN	a [mm]	L [mm]	Pipe Dxw	for insertion length
ESP-W-ISO-8	ISO8	32	59	13,5 x 1,6	TFP-.../ 037
ESP-W-ISO-10	ISO10	34	63,5	17,2 x 1,6	TFP-.../ 037
ESP-W-ISO-15	ISO15	36	63	21,3 x 1,6	TFP-.../ 037
ESP-W-ISO-20	ISO20	55	88	26,9 x 1,6	TFP-.../ 037

## DIN 11850 Series 2 DIN 11866 Series A

DIN 11850 Series 2 / DIN 11866 Series A				
Order Code	DN	L [mm]	Pipe Dxw	for insertion length
ESP-G-DIN2-10	10	70	13 x 1,5	TFP-.../ 037
ESP-G-DIN2-15	15	70	19 x 1,5	TFP-.../ 037
ESP-G-DIN2-25	25	100	29 x 1,5	TFP-.../ 037
ESP-G-DIN2-40	40	120	41 x 1,5	TFP-.../ 037
ESP-G-DIN2-50	50	140	53 x 1,5	TFP-.../ 037
ESP-G-DIN2-65	65	160	70 x 2,0	TFP-.../ 037
ESP-G-DIN2-80	80	180	85 x 2,0	TFP-.../ 037
ESP-G-DIN2-100	100	200	104 x 2,0	TFP-.../ 083

DIN 11850 Series 2 / DIN 11866 Series A					
Order Code	DN	a [mm]	L [mm]	Pipe Dxw	for insertion length
ESP-W-DIN2-10	10	35	62	13 x 1,5	TFP-.../ 037
ESP-W-DIN2-15	15	35	64,5	19 x 1,5	TFP-.../ 037
ESP-W-DIN2-20	20	40	69	23 x 1,5	TFP-.../ 037
ESP-W-DIN2-25	25	50	85	29 x 1,5	TFP-.../ 037

## DIN 11866 Series C OD-Tube

DIN 11866 Series C / OD-Tube / size acc. to ASME BPE 2002				
Order Code	DN	L [mm]	Pipe Dxw	for insertion length
ESP-G-ASME-1/2"	1/2"	95	12,7 x 1,65	TFP-.../ 037
ESP-G-ASME-3/4"	3/4"	102	19,05 x 1,65	TFP-.../ 037
ESP-G-ASME-1"	1"	108	25,4 x 1,65	TFP-.../ 037
ESP-G-ASME-1 1/2"	1 1/2"	120,5	38,1 x 1,65	TFP-.../ 037
ESP-G-ASME-2"	2"	146	50,8 x 1,65	TFP-.../ 037
ESP-G-ASME-2 1/2"	2 1/2"	160	63,5 x 1,65	TFP-.../ 037
ESP-G-ASME-3"	3"	170	76,2 x 1,65	TFP-.../ 037
ESP-G-ASME-4"	4"	210	101,6 x 2,11	TFP-.../ 083

DIN 11866 Series C / OD-Tube / size acc. to ASME BPE 2002					
Order Code	DN	a [mm]	L [mm]	Pipe Dxw	for insertion length
ESP-W-ASME-1/2"	1/2"	47,5	74,5	12,7 x 1,65	TFP-.../ 037
ESP-W-ASME-3/4"	3/4"	50,8	80,3	19,05 x 1,65	TFP-.../ 037
ESP-W-ASME-1"	1"	54	85	25,4 x 1,65	TFP-.../ 037

### Order Code

Model	Type	Pipes	Diameter	Surface	Delta Ferrite	Sulfure Content
Build-in system straight line	ESP-G-	DIN1 (see spec. style pipe) DIN2 ISO ASME	10...50 10...100 8...80 1/2"...4"	0,8 $R_a \leq 0,8\mu\text{m}$ 0,6 $R_a \leq 0,6\mu\text{m}$ 0,4 $R_a \leq 0,4\mu\text{m}$	x <1,0% 0,5 <0,5% BN Baseler Norm II	x <0,030% SA acc. to ASME
Build-in system angled	ESP-W-	DIN1 DIN2 ISO ASME	10...15 10...25 8...20 1/2", 3/4", 1"			

Order example: ESP - G - DIN2 - 10 / 0,6 / 0,8 / BN / SA

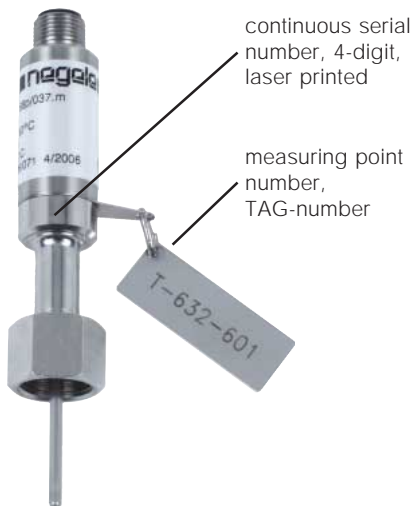

continuous serial number, 4-digit, laser printed

measuring point number, TAG-number



### Pipe identification:

- material, electro polished
- pipe dimensions
- charge number of the pipe, serial number
- charge number of the weld-on bushing



material and charge number of the weld-on bushing

### Customised labelling of the packaging

Bestell-Nr.: 99/4559987/310  
Typ: TFP-58p/160 m 0-150°C  
Modernisierung H84,  
Warenann. Baufeld, G74, Halle 1  
Gewicht: 550g

TYP.: ESP-G-ASME-G 1.5"  
Teilekennzeichen: 2EW 611  
Modernisierung H84,  
Warenann. Baufeld, G74, Halle 1  
Inhalt: 10 Stück

Anlieferung Projekt  
Modernisierung H84,  
Warenann. Baufeld, G74, Halle 1

### Surface Quality



In order to provide favourable conditions for sterile production, the surface must be smooth and non-porous down into the microscale range. Overlapping areas, or material laminations, must be avoided as far as possible on account of the dead spaces that result, since these areas are difficult or impossible to clean and therefore represent ideal breeding grounds for germs and bacteria.

Moreover the dimensions (including height!) must be kept as small as

possible to minimise the influences of the surfaces in contact with the product. Such surfaces can be obtained by means of electropolishing. In the pharmaceutical sector, but not only there, the quality of the surface is generally defined in terms of the "R<sub>a</sub>" - roughness. A surface with R<sub>a</sub> ≤ 0.8µm is normal, in special cases also R<sub>a</sub> ≤ 0.6µm and even R<sub>a</sub> ≤ 0.4µm. All these qualities can be achieved by machining appropriately good quality steels and electropolishing them for a sufficiently long period of time. Ra is the arithmetic average of all protuberances on the surface y over a certain measurement distance L in the x-direction.

### Delta Ferrite



The higher the delta ferrite content (DF), the more magnetic phases are present in the austenitic structure. These arise as a result of thermal effects, e.g. during welding and turning. The strain-induced martensite that is formed here leads to increased susceptibility to corrosion for the workpiece and is therefore undesirable.

According to DIN 11866 Table B.1 differentiation can be made between three DF classes:

- Class 1: < 3.0 % delta ferrite in the as-supplied state
- Class 2: < 1.0 % delta ferrite in the as-supplied state
- Class 3: < 0.5 % delta ferrite in the as-supplied state

In order to achieve DF Classes 2 and 3, the tubes must in general be "solution annealed" before delivery. The solution annealing takes place at temperatures between 1020°C and 1150°C, depending on the material.

1.4435 stainless steel has a reduced delta ferrite content much lower than 1 % compared with 1.4404. The increase caused by welding processes can be minimised by the use of suitable welding materials, shielding gas, and the correct current, so that the delta ferrite content at least remains below 3 %.

If the whole work piece is required to have a delta ferrite content less than 0.5 %, it must be ordered in accordance with "Baseler Norm II".

The reduction of the delta ferrite must not be too excessive, however, because with too low a content there is a tendency for the stainless steel to form cracks during machining or welding. Specified Delta-Ferrit values are valid for delivery condition. Mechanical treatments after delivery can increment the Delta-Ferrit.

### USP Class VI



Relative new and initialized from US market is a new qualification of product contacting plastics. Primary a requirement from the medical sector this will get a standard of the pharmaceutical industries in the future for a lot of applications. Plastics and elastomers according to the so called USP Class VI standard is suitable for implantation into the human body without any complications. Presently this is the highest requirement to material harmlessness.

## Inspection Certificate Weld Seam



Optionally there is a qualification of the weld seam available. In this case the weld seam is stressed with 20bar water pressure for 10 minutes and tested for leaks. If the test is passed an inspection certificate is issued according to DIN EN 10204-3.1 guideline 97/23/EG, AD2000 HP 100R. Every work piece will be tested (no random examination)!

## 3A-Standards



In 1920 three US associations published directives for milk pipe connections. Hence the name 3A, for 3 Associations. These organisations are:

- International Association of Milk, Food and Environmental Sanitarians (IAMFES)
- United Public Health (UPH)
- Dairy Industry Committee (DIC)

In 1944 the body of regulations, which in the intervening period had become more comprehensive, was accredited by the US

Government. Over 50 standards have been published, primarily for the milk industry. Other sectors, in particular the pharmaceutical industry, are oriented towards these standards or prescribe them as mandatory.

## FDA



The "Food and Drug Administration" (FDA) is a US authority that issues approvals for agents, foodstuffs, cosmetics and pharmaceutical products. In addition it generates recommendations for the use of materials in facilities in the foodstuffs and pharmaceutical industries. This supplementary task is administered because the individual components, materials and design details have significant influence on the quality of the end product.

An "FDA Approval" can only be issued for a product generated in the particular facility in question. For components and

materials there is no FDA approval; these parts are "FDA listed" in terms of their innocuousness if in direct contact with the product. The FDA directives are published as so-called "Codes of Federal Regulations" (CFR...). The 21 CFR 170 - 199 directives have a special significance, in particular with regard to material selection for sensor manufacturers. They contain a listing of specifications for plastics. Thus, 21 CFR 177.2415, for example, contains the plastic PEEK that is often used in the food and pharmaceutical market sectors.

## ASME

In the pharmaceutical sector one often comes across the requirement to deliver tubes in 1.4435 to meet ASME. In most cases what is meant here is simply the tube dimensions with regard to diameter and wall thickness. In this event ASME is identical with the ODT dimensions.

However, ASME BPE 2002 also defines a minimum and maximum content for elemental sulphur, which in fact must lie between 0.005% and 0.017%. According to ASME regulations this requirement applies, however, just to tube ends that are still to be automatically welded, and not to those that are already welded. The definition of a certain range for the sulphur content makes total sense, since parts with strongly differing sulphur content would deflect the arc during welding and as a result would lower the quality of the weld seam.

Otherwise the value prescribed in the German Key to Steel for 1.4435, or the value defined in AISI for 316L of 0.030% sulphur content applies.

Comment: ASME BPE 2002 specifies not only the sulphur content of the work piece, but also the contents of other materials contained in the steel such as nickel, molybdenum, etc. These however essentially correspond to the values in the German Key to Steel, which applies in Europe.

## Order Code for Certificates

Certificate	Type
Surface Quality Certificate	- Ra
Delta-Ferrit Measurement Certificate	- DF
Weld Seam Examination Certificate	- DP
Order example:	ESP-G-DIN2-10-0,4-Ra-DF-DP

## Note:

Additional prices for certificates are quoted per work piece!

Dimensioned Drawings of Adapters (other standard sizes are available)

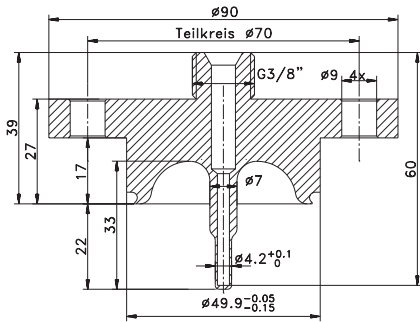

for BioControl  
ESP-B

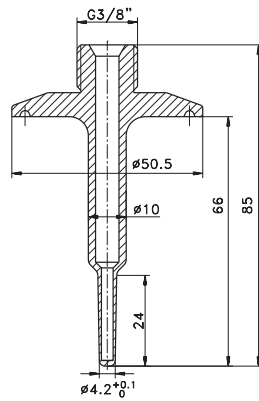

for TriClamp  
ESP-C

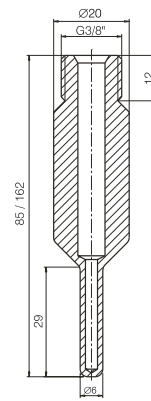

Thermowell  
ESP-E

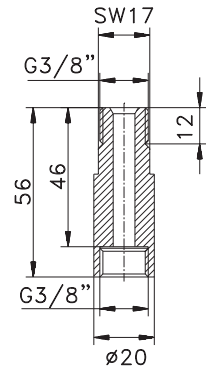

Extension  
ESP-VL

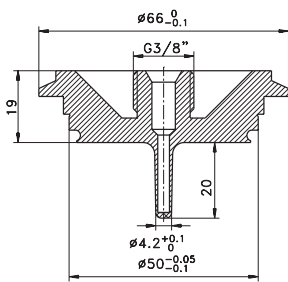

for Varivent  
ESP-V25-037

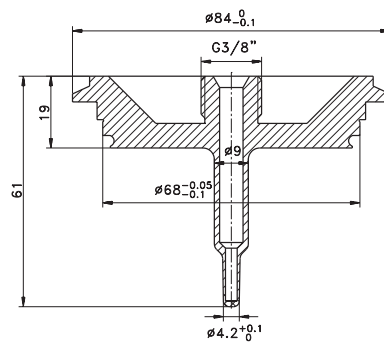

for Varivent  
ESP-V40-059

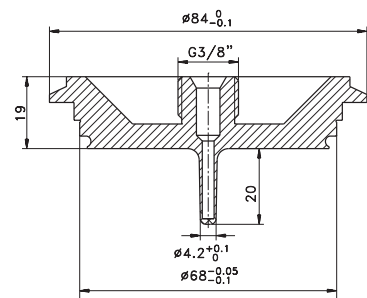

for Varivent  
ESP-V40-037

## Accessories

For specification: look at separate product information



Calibration device  
htr



Simulator  
hsg-3



Precision-temperature-device  
htm-p



Transmitter for Temperature  
Sensors mpu-...



Programming Adapter for  
Temperature Transmitters  
mpu-p



PVC-cable with fitting  
M12-PVC